

MEGABLOCK foam cutters

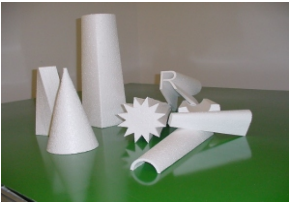

*Over 1500 foam cutters
in over 50 countries ...*



Algeria, Argentina, Australia, Austria, Bahrain, Belarus, Bulgaria, Canada, China, Czech Republic, Costa Rica, Denmark, Finland, France, Germany, Greece, Hungary, Iceland, India, Israel, Italy, Jordan, Latvia, Lithuania, Kuwait, Mexico, Malaysia, Norway, Poland, Puerto Rico, Republic of South Africa, Romania, Russia, Saudi Arabia, Serbia & Montenegro, Slovakia, Slovenia, Spain, Sweden, Taiwan, Turkey, Ukraine, United Arab Emirates, United Kingdom, United States of America and more...





ABOUT MEGAPLOT

MegaPlot was established in 1995 when its founders built their first prototype of a foam cutter. For the past 12 years MegaPlot has grown and has become the world leader in hot wire foam cutting machines. Out of a company known to a few, we have developed into the biggest foam cutters manufacturer in the world with **over 1500 units installed in over 50 different countries.**

Currently our main markets include USA, Germany, Italy, France, Spain, Canada, Poland, Middle East, China, Mexico as well as Former Soviet Republics. In all these countries - and over 40 others - our foam cutters are known for their **highest quality, reliability, ease of use and versatility.**

The best proof confirming our leading position on the market is the more and more common - although rarely successful - practice of imitating and copying of our machines by our competitors. We do not treat this as a threat but rather a continuous stimulus for further development and improvement of our products. Our experience as well as the highest quality materials we use enable us to produce the best thought-over and defect-proof machines.

That is why we are confident to offer a complete **5-year warranty** on all our foam cutters a hard-to-find phenomenon on the machinery market.

TABLE OF CONTENTS

	PAGE
ABOUT MEGAPLOT, TABLE OF CONTENTS	3
WHAT IS A FOAM CUTTER?	3
HOW DOES A FOAM CUTTER WORK?	4-7
WHAT ARE FOAM CUTTERS USED FOR?	8-11
AVAILABLE SERIES & MODELS	12
SERIES COMPARISON	13
"P" SERIES - 1 CUTTING WIRE	14
"T" SERIES - 1 OR TWO CUTTING WIRES	15
"MW" SERIES - 10 CUTTING WIRES	16
ACCESSORIES - TURNTABLE	17
ACCESSORIES - LATHE	28
ACCESSORIES - SHAPEWIRE TOOL	19
ACCESSORIES - INDEPENDENT AXIS	20
ACCESSORIES - DOUBLEWIRE, WIRE TENS.	21
FOAMSHAPER SOFTWARE	22-23
CUTTING WIRE, FOAM	24
WARRANTY	25
R&D, MEGAPLOT IN NUMBERS	26
FREQUENTLY ASKED QUESTIONS	27
CONTACT INFO	28

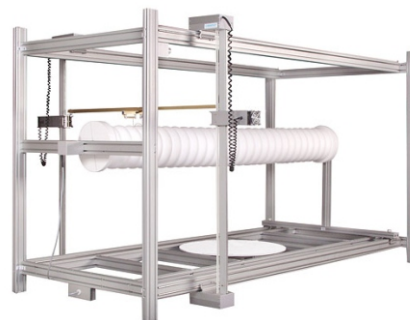



WHAT IS A FOAM CUTTER?

The foam cutter is a machine controlled by a PC computer capable of cutting any 3D objects out of extruded and expanded polystyrene foams (EPS and XPS). The cutting is performed with a resistant hot wire moving in the vertical and horizontal axes through the use of stepper motors controlled by an electronic controller connected to a PC and controlled with our FoamShaper software.

Almost any 2D or 3D shape prepared in graphics software (CorelDraw, AutoCad, Rhino3D, etc.) can be loaded in FoamShaper and cut in foam in minutes! All our units can be equipped with TurnTables, Lathes, ShapeWire Tools and other additional add-ons making them truly versatile and limited only by the operator's imagination.

For more information regarding these and other elements (e.g. ShapeWire Tool), please see the following pages.



There are up to 8 **Stepper Motors** in each of our foam cutters — 4 for the X axis, 2 for the Y axis, 1 for TurnTable and 1 for Lathe. These high-quality 3 Amp motors guarantee great accuracy and longevity



The Electronic Controller is an independent unit of our own design and production responsible for the two-way communication between the foam cutter and your computer, controlling all parameters of the foam cutter.

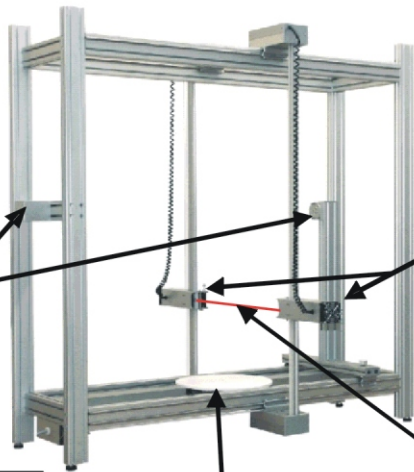

Custom-Designed Heavy Duty Anodized Aluminum Extrusion **Profiles** make our foam cutters' construction light-weight and extremely strong which enable amazing accuracy and repeatability of cuts.



The Wire/Fan Housing is where the straight cutting wire is mounted. The box holds a fan which cools the wire while cutting and a special spring compensating for hot wire stretching.



The Lathe is a fully automatic tool controlled by FoamShaper software which lets you cut all possible solids of revolution, such as columns, banisters etc. The material is mounted on a steel spikes located on a spike plate and on a lathe tail-stock.



Fully automatic **TurnTable** controlled by our FoamShaper software makes it possible to cut rotary figures, such as columns or spheres.

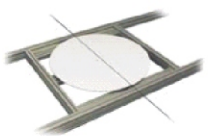

Our custom-made Titanium Allo Wire is very unique and is composed of Nickel, Chrome, Cobalt, Molybdenum and Titanium. It provides great tensile strength, lets you cut with very high speeds and lasts for a long time. Depending on the machine, we offer the following diameters: 0.25, 0.45 & 0.55mm





HOW DOES A FOAM CUTTER WORK?

2D CUTTING WITH THE STRAIGHT WIRE

In the picture below you can see a foam cutter cutting a logo in a block of foam. The trolleys with a resistant wire spread between them move in the X and Y axes following a tool path based on a drawing prepared in graphics software (e.g. CorelDraw or AutoCad). In this case, the third dimension (logo thickness) corresponds exactly to the thickness of the block of foam. This standard cutting method is available in all our hot wire foam cutters.

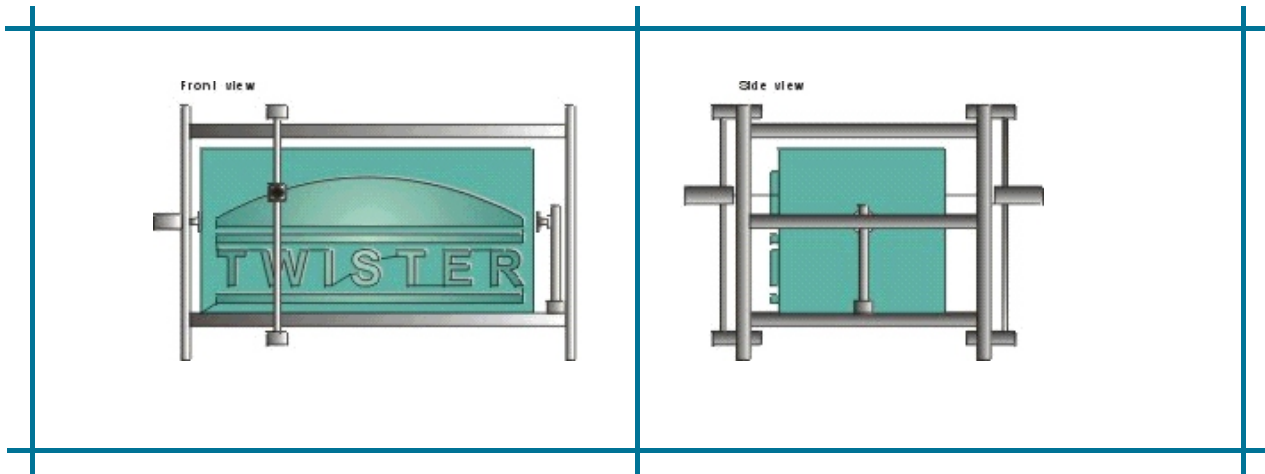

STRAIGHT WIRE + LATHE

All our foam cutters can be equipped with a lathe which is used to cut all kinds of rotated shapes such as columns, banisters, etc. Here the foam is mounted on steel spikes (located on the spike plate and the lathe tailstock). The design process is very simple as the solid is defined with two lines only: the rotation axis and the external shape (this making e.g. CorelDraw sufficient for cutting such shapes). Depending on your requirements, the number of sides is set in FoamShaper (ranging from 1 up to 2000), which makes cutting a 4- or 6-sided column a very simple task. If you set the number of steps to a large value, you can obtain a perfectly smooth surface. Plus you can set the Lathe to rotate the foam while it is being cut which will result in a spiral shape.

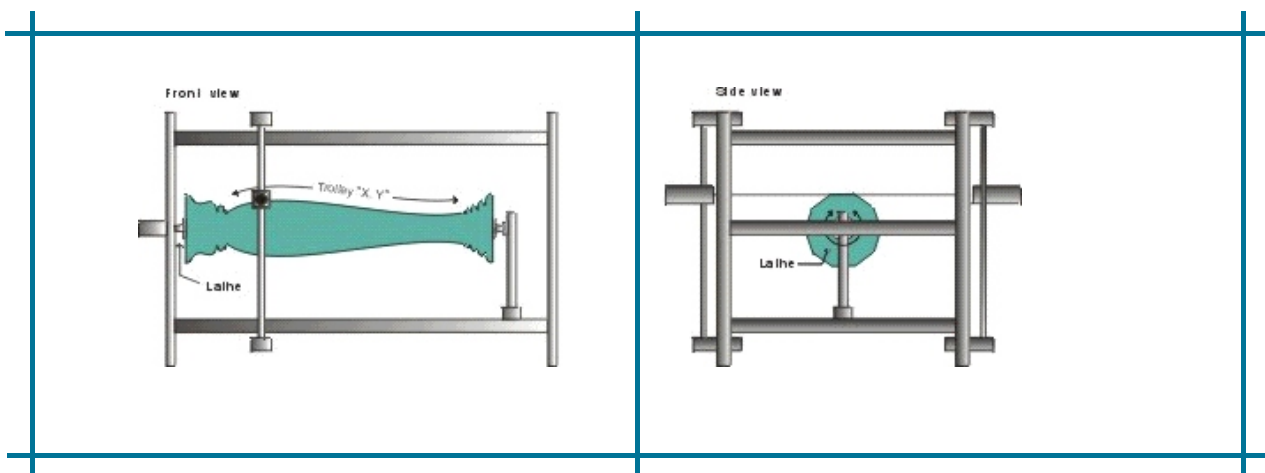



HOW DOES A FOAM CUTTER WORK? (CONT.)

SHAPEWIRE + LATHE

All our cutters can be equipped with a ShapeWire Tool which is used to temporarily replace the standard straight resistant wire. A 1-mm thick wire is mounted on the ShapeWire Tool and - with the use of Lathe or TurnTable rotations - is used to cut any shape it has been pre-bent to in a block of foam. The same tool is also used to make impressive incisions/chiseling.

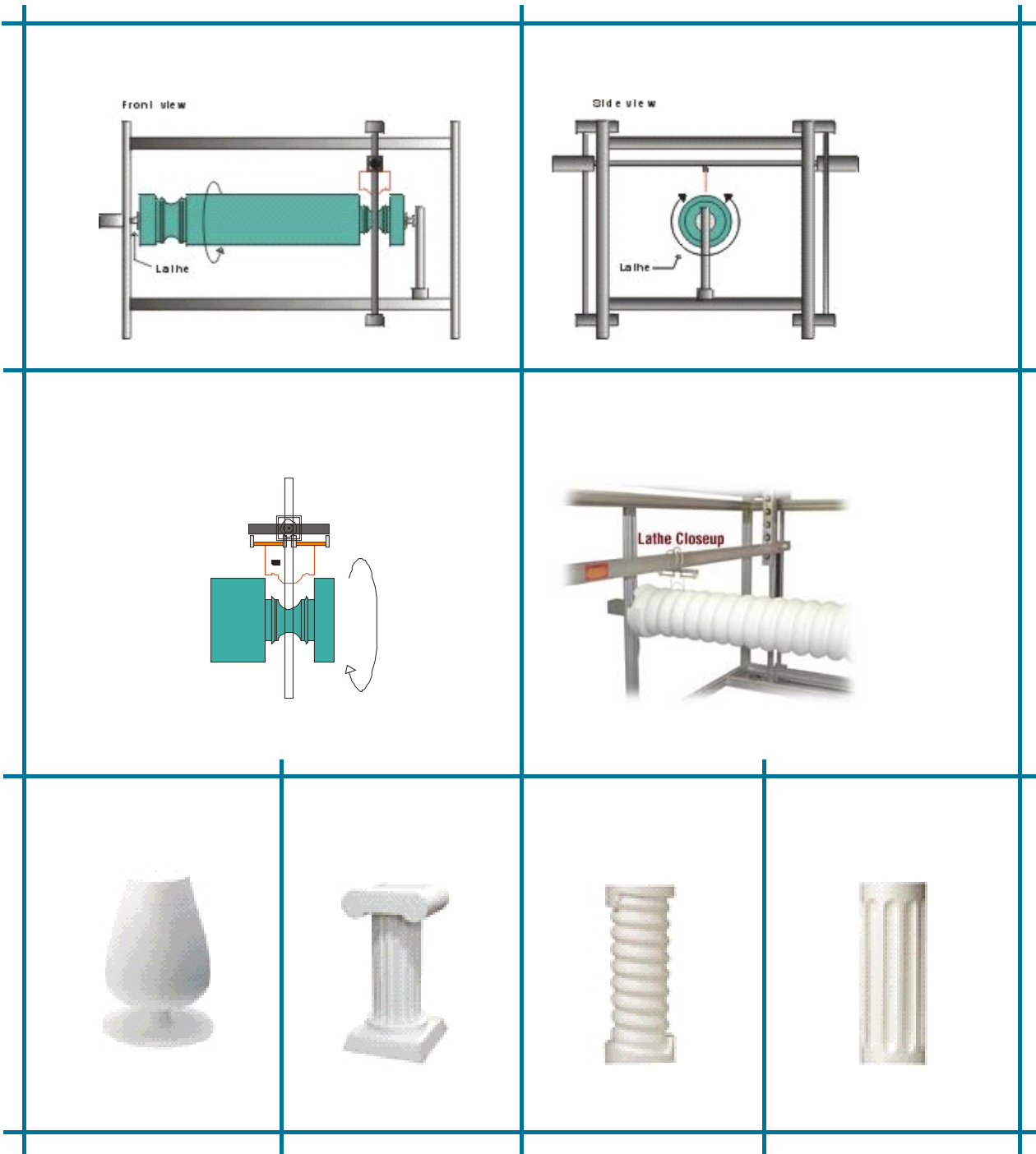



HOW DOES A FOAM CUTTER WORK? (CONT.)

TURNTABLE

All our foam cutters can be equipped with a Turn Table - a very useful and offering unlimited possibilities device enabling you to cut out all the solids of revolution, including the sphere. The Turn Table is computerized and works in unison with the Hot Wire to produce "flat" 3D objects.

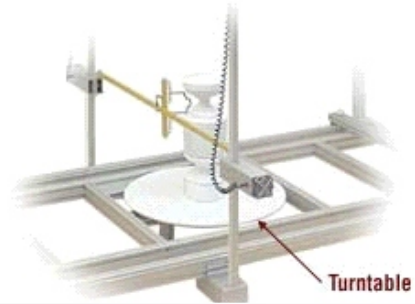

SHAPEWIRE TOOL & TURNTABLE

Cuts done with Lathe and Shapeable Wire can also be done with Turn Table and ShapWire Tool.

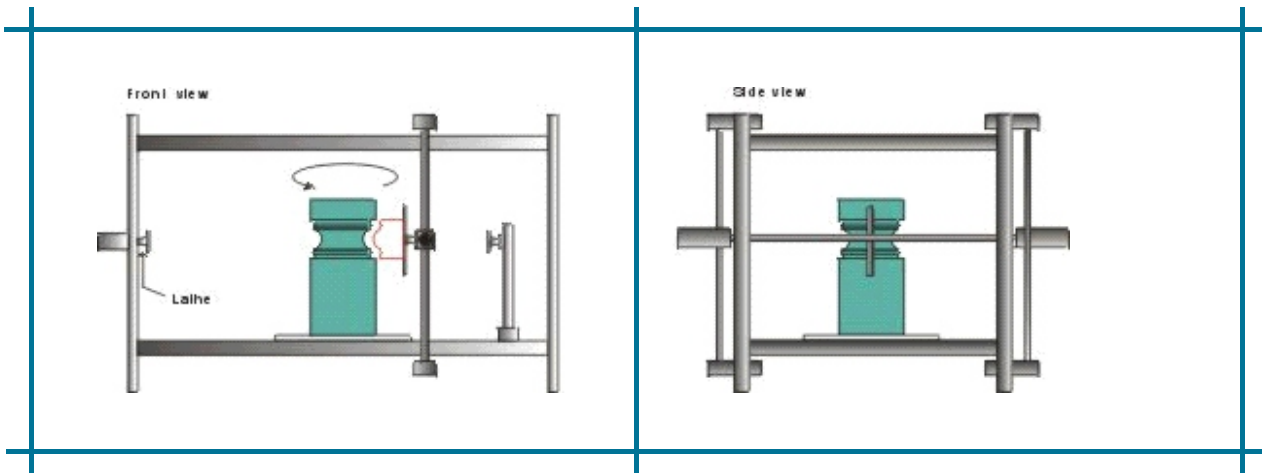

STRAIGHT WIRE & TURNTABLE

With the use of a turntable and a straight resistant wire you can also cut a sphere and all similar shapes.

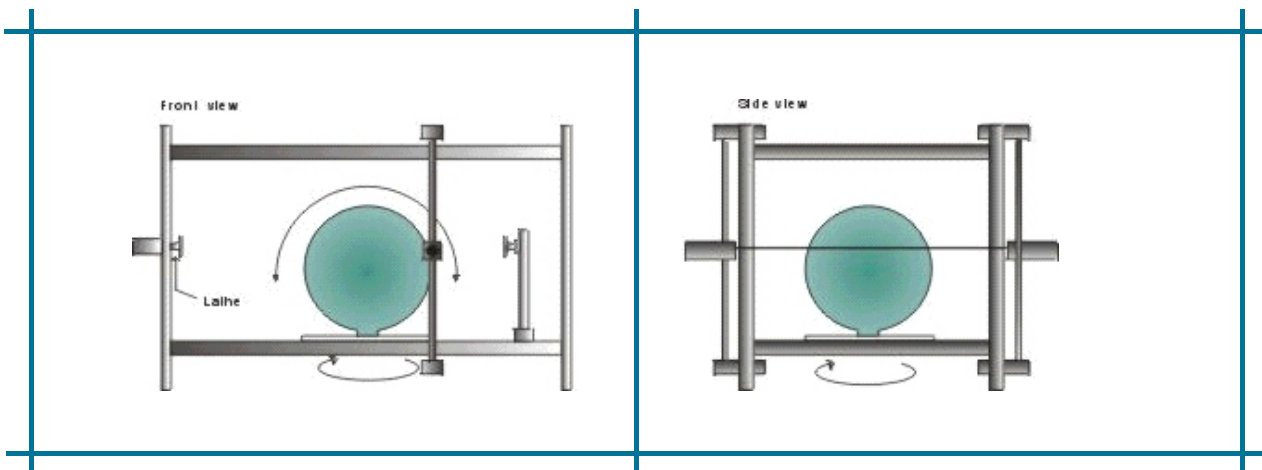



HOW DOES A FOAM CUTTER WORK? (CONT.)

SERIAL CUTS

FoamShaper software (standard for all foam cutter models) allows automatic serial cutting of multi-various objects/solids. The drawings (side views) can be created in Corel Draw. You may use pictures from a digital camera (converted to HPGL.plt files) for drawing preparation. This method (although time consuming) gives perfect opportunities of creating almost any 3D object.

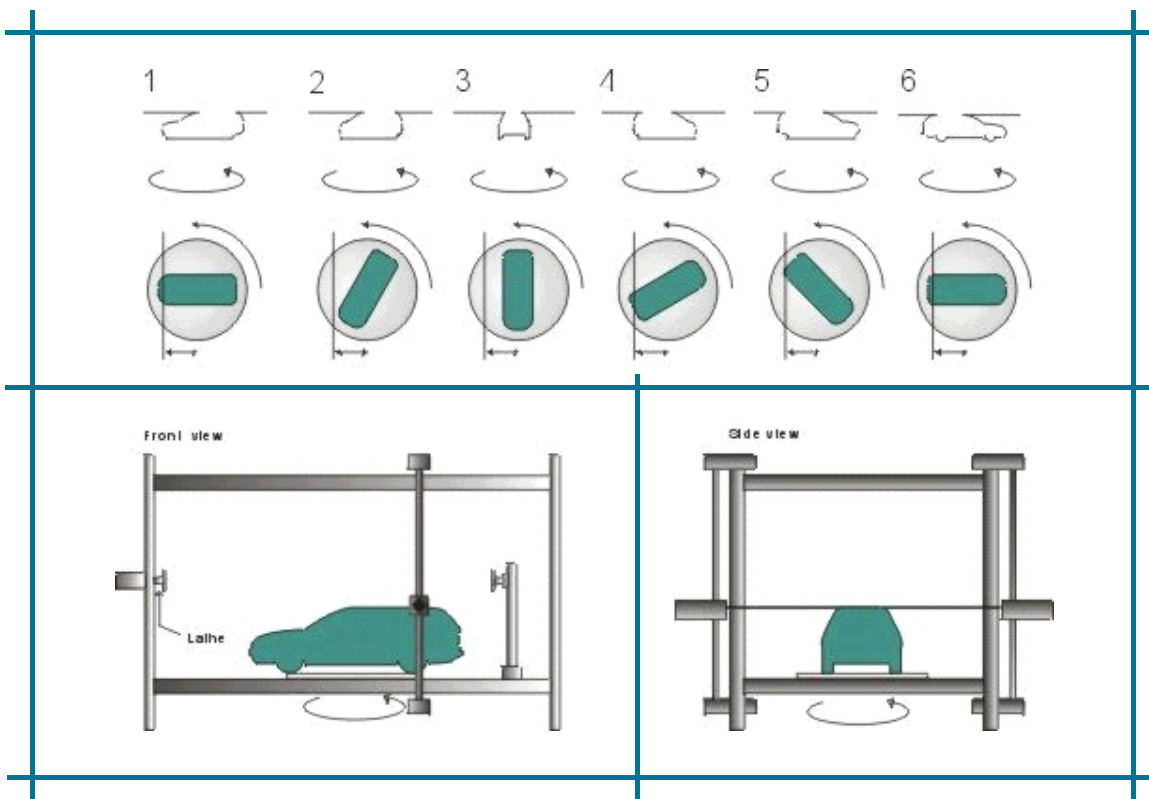

SERIAL CUTS FROM 3D RAW MODELS

A new, unique and exciting feature in FoamShaper software for creating Serial Cut files from 3D RAW models. From now on it's gonna be granny-simple to cut a 3D shape out of a 3D model on any MegaPlot foam cutter equipped with a TurnTable. All you need is a MegaPlot foam cutter with a TurnTable and a free FoamShaper upgrade. See following pages for more details.

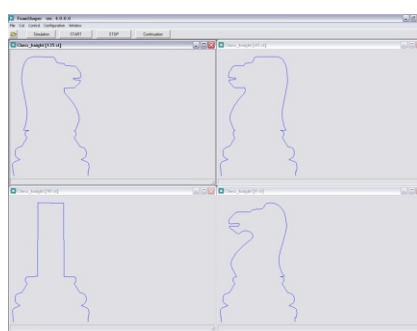
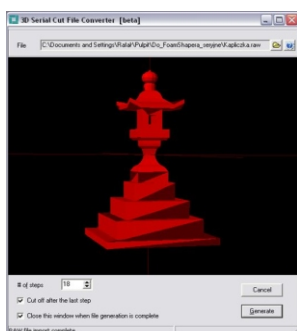



WHAT ARE FOAM CUTTERS USED FOR?

Foam cutters can be used for a wide variety of cutting applications. They can cut virtually anything out of expanded and extruded foam — your imagination is their only limit. Some of the common applications include:

- * Complicated 3D Logos
- * Sign Letters
- * Graphics
- * Architectural Shapes
- * Architectural Scale Models
- * Fair Stalls
- * Film or Theatre Props, Shapes and Backdrops
- * Hobby & Crafts
- * PreCast Concrete Molds
- * Pipe Insulation
- * Columns
- * Store Props & Displays
- * P.O.P. Displays
- * Prototype Products
- * All kinds of Packaging
- * Theme Props
- * Amusement

LETTERING & LOGOS

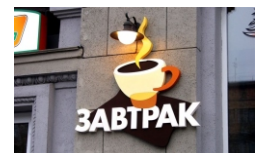



MEGAPLOT

FOAM CUTTERS & ROUTERS MANUFACTURER

www.megaplot.com



WHAT ARE FOAM CUTTERS USED FOR? (CONT.)

FAIR, THEATRE AND FILM DECORATIONS

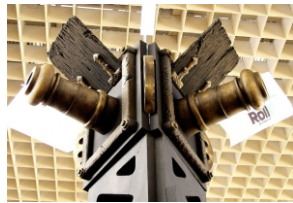
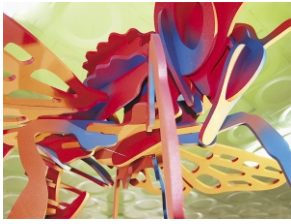

PACKAGING

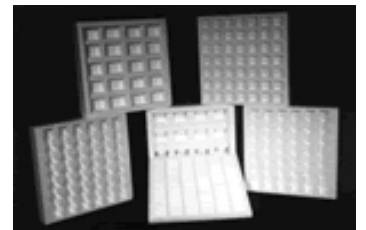
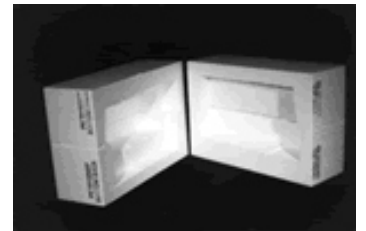
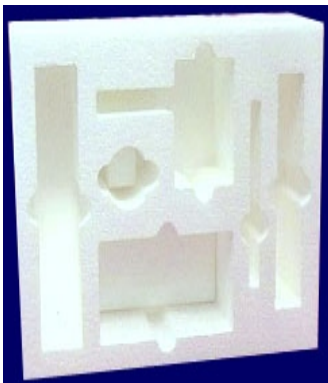
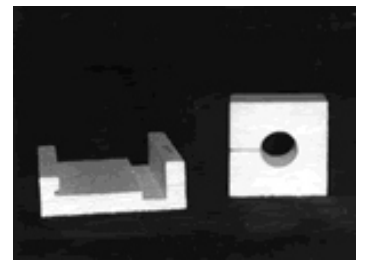



MEGAPLOT

FOAM CUTTERS & ROUTERS MANUFACTURER



www.megaplot.com

WHAT ARE FOAM CUTTERS USED FOR? (CONT.)

ARCHITECTURAL ELEMENTS

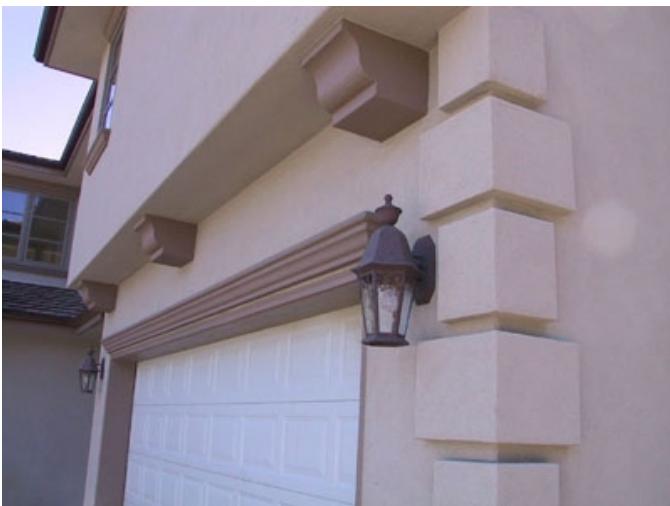



WHAT ARE FOAM CUTTERS USED FOR? (CONT.)

THERMAL INSULATION OF A HOUSE BUILT IN THE PRAFEA SYSTEM - ON-SITE REPORT

FOAM: FS 20, **THICKNESS:** 15,5 cm, **WALL AREA:** 184 m²., **WORK TIME:** 7 hours, **WORKERS:** 2

A T 3000 Small MegaPlot foam cutter was assembled at the construction site in less than 30 minutes. It was used to cut different-shape 15,5 cm-thick sheets out of 50x120x300 cm foam blocks

NOTES:

- as per the investor's wish, all corners are round (impossible to achieve when using standard foam sheets)
- each foam element was covered with a thin layer of glue and mounted on the wall with 6 plastic pegs
- thanks to the high precision of computer-controlled cutting, there are no thermal bridges between the adjoining elements, not even in the difficult window-area.





AVAILABLE SERIES

"P 60" SERIES - AFFORDABLE AND RELIABLE SIGN SHOP SOLUTION



- cutting wire length: **60 cm**
- number of cutting wires: **1**

- **available options:**
 - TurnTable/Lathe
 - ShapeWire Tool

"T" SERIES - VERSATILE AND PERFECT FOR AND DECORATION AND ARCHITECTURE



- cutting wire length: **60, 130, 150, 250 or 300 cm**
- number of cutting wires: **1 or 2**

- **available options:**
 - TurnTable
 - Lathe
 - ShapeWire Tool
 - DoubleWire
 - TitaniumWire
 - Independent Axis Control
 - Pneumatic Wire Tensioning

"MW" SERIES - INDUSTRIAL SOLUTION FOR LARGE SERIES OF IDENTICAL SHAPES



- cutting wire length: **130, 150, 250 or 300 cm**
- number of cutting wires: **10**



- **available options:**
 - TurnTable
 - Lathe
 - ShapeWire Tool
 - Pneumatic Wire Tensioning

AVAILABLE MODELS

		Machine Width = Hot Wire Length				
		60 cm 2 feet	130 cm 4 feet	150 cm 5 feet	250 cm 8 feet	300 cm 10 feet
Machine Length	130 cm 4 feet	P 60 Small T 610 Small	T 1300 Small MW 1300 Small	T 1500 Small MW 1500 Small	T 2500 Small MW 2500 Small	T 3000 Small MW 3000 Small
	250 cm 8 feet	P 60 Medium T 610 Medium	T 1300 Medium MW 1300 Medium	T 1500 Medium MW 1500 Medium	T 2500 Medium MW 2500 Medium	T 3000 Medium MW 3000 Medium
	305 cm 10 feet	P 60 Large T 610 Large	T 1300 Large MW 1300 Large	T 1500 Large MW 1500 Large	T 2500 Large MW 2500 Large	T 3000 Large MW 3000 Large



SERIES COMPARISON

	P 60 series	T series	MW series
WORK AREA:			
Height:	129 cm 4 feet		
Width (wire length):	60 cm 2 feet	60, 130, 150, 250 or 300 cm 2, 4, 5, 8 or 10 feet	130, 250 or 300 cm 4, 8 or 10 feet
Length:	129 cm, 244 cm or 305 cm 4, 8 or 10 feet		
WIRE & CUTTING:			
Number of Cutting Wires:	1	1 or 2	10
Cutting Wire Type:	NiCr	NiCr or Titanium Alloy*	Titanium Alloy
Cutting Wire Thickness:	0.15 mm	0.15, 0.25 or 0.45 mm	0.25 or 0.45 mm
Wire Movement:	stepper motors, belt driven on ball bearing transport wheels		
Wire Tensioning:	automatic, wire tension maintained at all times		
Wire Tensioning Type:	spring	spring or pneumatic*	spring or pneumatic*
Wire Heating:	instant ON/OFF, wire heats only when moving or turned manually on in FoamShaper		
Maximum Wire Speed:	280 cm/min	300 cm/min	100 cm/min
Accuracy:	0,5 mm/meter		
Resolution:	0,01 mm		
Repeatability:	0,01 mm/meter		
OPTIONAL EQUIPMENT AVAILABILITY:			
TurnTable:	yes	yes	yes
Lathe:	yes	yes*	yes
ShapeWire Tool:	yes	yes*	yes
DoubleWire:	no	yes	no
Independent Axis Control:	no	yes*	no
Titanium Alloy Wire:	no	yes*	yes
Pneumatic Wire Tensioning:	no	yes*	yes*
GENERAL INFO:			
Machine construction:	custom-made anodized aluminum extrusion profiles		
Accessibility:	full access from all four sides		
Power requirements:	110 or 220 Volt 50 or 60 Hz	110 or 220 Volt 50 or 60 Hz	220 Volt 50 or 60 Hz
Operating Environment:	Temperature: 32°F - 104°F or 0 - 40°C Humidity: 95%		
Computer operating system:	Windows 98 or later (including XP)		
Computer power required:	Pentium class PC with a free serial port (USB for selected models)		
Controlling software:	FoamShaper, comes free of charge with all foam cutters, free upgrades		
Design software:	All software exporting HPGL.plt or dxf files (i.e. CorelDraw, AutoCAD and similar)		
Warranty:	5 years, covers all electronics and mechanics, freight cost excluded		
Basic Package includes:	foam cutter, electronic controller, FoamShaper software, a roll of wire, operational and assembly manuals, 5-year warranty, year-round technical support (e-mail and phone)		
Basic Package excludes:	PC, graphics software (e.g. CorelDraw), optional equipment listed above		
			

* selected models only



"P 60" SERIES = 1 CUTTING WIRE

AFFORDABLE AND RELIABLE SIGN SHOP SOLUTION



- cutting wire length: **60 cm**
- number of cutting wires: **1**

- **available options:**
 - TurnTable/Lathe
 - ShapeWire Tool

This is an inexpensive and very popular series, perfect for start-up sign shops and other small businesses from the advertising business. Comes in three different lengths and can be equipped in TurnTable/Lathe as well as ShapeWire Tool.

Main features:

- simple, inexpensive but fully versatile
- small, but big enough for any kind of lettering, logos, columns, etc.
- extremely easy to self-assemble
- cutting wire: 610 mm
- height: 1220 mm
- length: 1220 mm, 2440 mm or 3050 mm
- available options (Lathe/TurnTable & ShapeWire Tool)
- packed in one box (cheap freight)
- comes complete with the electronic controller & FoamShaper

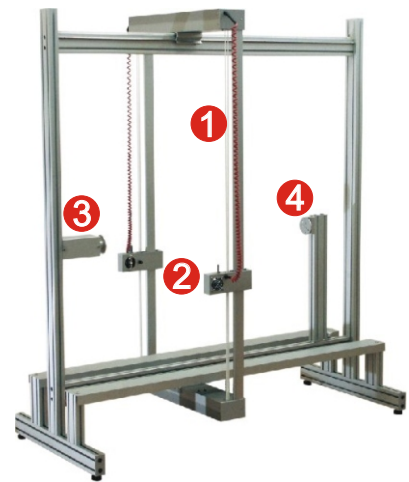

1. cutting frame
2. wire/fan housings
3. lathe
4. lathe tailstock

P 60 models will cut anything small T series cutters can cut!

Cutting Frame

Instead of two separate trolleys, this frame comes in one piece (top, bottom and both sides). It makes the assembly a piece of cake.

Lathe

The Lathe can be easily re-installed to where the blue arrow points and will then act as a fully functional **TurnTable**.

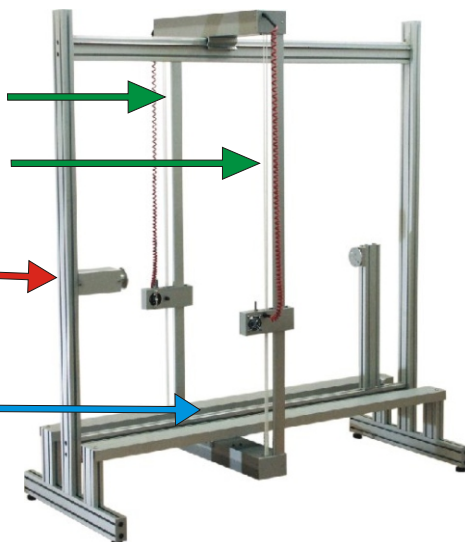

Introductory Package includes:

- the P 60 foam cutter
- the electronic controller
- FoamShaper software*
- 5-year warranty**
- a roll of resistant wire (100 grams)
- operational and assembly manuals
- year-round technical support (e-mail and phone)

Introductory Package does not include:

- PC necessary to operate the machine
- design graphics software (recommended: CorelDraw)
- paid options (TurnTable, Lathe, etc.)
- freight to your country

* free upgrades included

** warranty: the 5-year warranty covers both electronics and mechanics. Freight cost excluded.



"T" SERIES = 1 OR 2 CUTTING WIRES

VERSATILE AND PERFECT FOR AND DECORATION AND ARCHITECTURE



- cutting wire length: **60, 130, 150, 250 or 300 cm**
- number of cutting wires: **1 or 2**

- available options:

- TurnTable
- Lathe
- ShapeWire Tool
- DoubleWire
- TitaniumWire
- Independent Axis Control
- Pneumatic Wire Tensioning

This is a very popular series among our customers due to a wide variety of available sizes and optional equipment. All the T series cutters can be equipped in the DoubleWire feature (two cutting wires) and the majority of them can come with a TurnTable, Lathe, ShapeWire Tool, Independent Axis Control and many other features which turn your cutter into a truly versatile one. While custom-made machines are of course available, the wide choice standard sizes in the T series satisfies the majority of our customers.



- | | |
|---------------------------|--------------------|
| 1. front trolley (top) | 5. lathe |
| 2. front trolley (bottom) | 6. lathe tailstock |
| 3. back wire/fan housing | 7. turntable |
| 4. front wire/fan housing | |

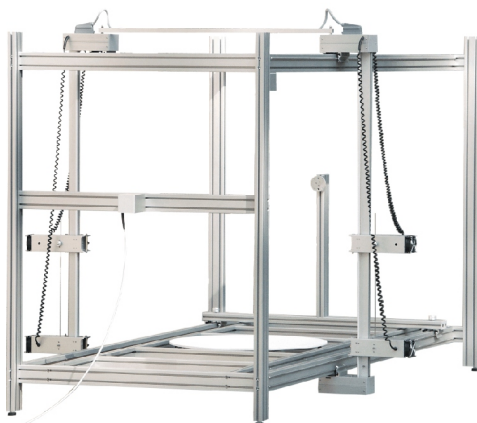

T 1300 Medium
with TurnTable, Lathe and DoubleWire

Introductory Package includes:

- the foam cutter
- the electronic controller
- FoamShaper software*
- 5-year warranty**
- a roll of resistant wire (100 grams)
- operational and assembly manuals
- year-round technical support (e-mail and phone)

Introductory Package does not include:

- PC necessary to operate the machine
- design graphics software (recommended: CorelDraw)-
- paid options (TurnTable, Lathe, etc.)
- freight to your country

* free upgrades included

** warranty: the 5-year warranty covers both electronics and mechanics.



"MW" SERIES = 10 CUTTING WIRES

INDUSTRIAL SOLUTION FOR LARGE SERIES OF IDENTICAL SHAPES



- cutting wire length: **130, 150, 250 or 300 cm**
- number of cutting wires: **10**
- **available options:**
 - TurnTable
 - Lathe
 - ShapeWire Tool
 - Pneumatic Wire Tensioning

This is a truly industrial series with up to ten wires cutting simultaneously the very same shape. Imagine the time and money you can save by having e.g. ten cornices cut at the same time. Depending on your needs, the wire length available varies from 130 cm to 300 cm. Pneumatic wire tensioning is available in the MW 2500 series as a paid option and comes standard for the MW 3000 series. To achieve best performance possible, all the MW models come standard with the TitaniumWire (great cutting quality and speed as well as wire durability). Optionally, all these cutters can be equipped in TurnTable, Lathe or ShapeWire Tool.

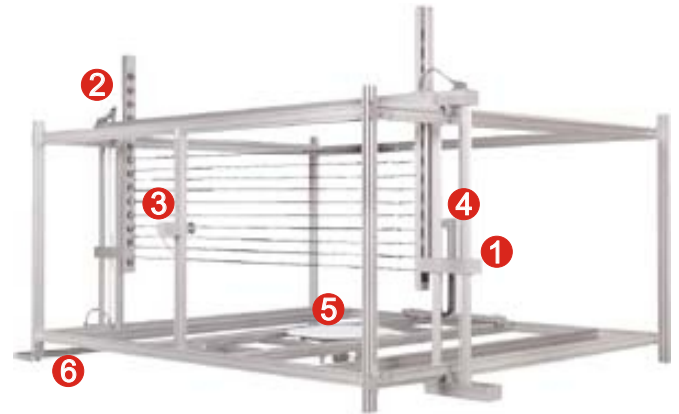

1. front trolley
2. back trolley
3. lathe
4. lathe tailstock
5. turntable
6. cable chain



**MW 2500 Medium
with TurnTable and Lathe**

Introductory Package includes:

- the foam cutter
- the electronic controller
- FoamShaper software*
- 5-year warranty**
- a roll of Titanium Alloy wire (100 grams)
- operational and assembly manuals
- year-round technical support (e-mail and phone)

Introductory Package does not include:

- PC necessary to operate the machine
- design graphics software (recommended: CorelDraw) -
- paid options (TurnTable, Lathe, etc.)
- freight to your country

* free upgrades included

** warranty: the 5-year warranty covers both electronics and mechanics. Freight cost excluded.



ACCESSORIES: TURNTABLE

Our FoamShaper-controlled, fully-computerized TurnTable is an optional device available for all our foam cutters. The high quality stepper motor fixed to a state-of-the-art planetary transmission turns your material while it's being tooled by either the straight, resistant hot wire or the optional ShapeWire. The TurnTable allows the operator to produce all kinds of 3D shapes, both symmetrical (e.g. sphere, columns) and asymmetrical (e.g. spray bottle, car, etc.).

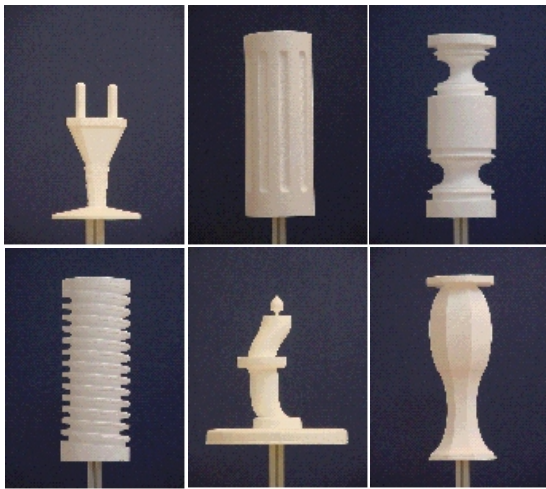
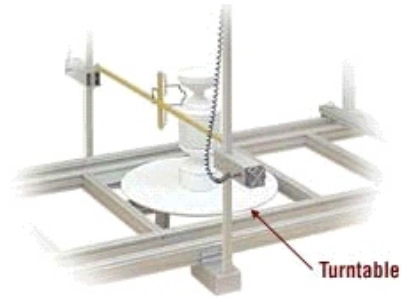

Available cutting modes:

1. Symmetrical shapes (spheres, columns, base caps, etc.).

1.1. TurnTable + HotWire

The operator prepares a single silhouette view of the required object. Once it's loaded into FoamShaper, the operator sets the required number of facets (e.g. four for a four-sided column, thirty for a smooth sphere, etc.). FoamShaper automatically determines the TurnTable rotations and starts cutting. After each step the HotWire stops and the material rotates (optionally the material may be rotating while the HotWire is cutting, in which case the operator only needs to specify the required rotation; the result is a twisted object). The steps are repeated the number of times equal to the number of facets the operator had set. It is a fully automated process: once the material is placed on the TurnTable, the file loaded and number of facets determined, the foam cutter does everything else and delivers your final product in no time.

1.2. TurnTable + ShapeWire

For this process, the operator pre-bends a piece of 1 mm thick ShapeWire. Once ready and mounted on the ShapeWire Bar, the operator prepares a simple tool-path type of file which tells the cutter where the ShapeWire is to enter and exit the material. Possibilities are endless as this process allows the operator to cut a groove column, a spiral column, a base cap, etc.

2. Asymmetrical shapes (a car, a plug, a spray bottle, etc.)

The operator prepares a number of silhouette views of the required object equal to the number of sides the final shape should have. In the case of the plug shown below, only four drawings are required. For more complicated shapes (see the car below), the number of drawings naturally increases. Once the drawings are ready and loaded into FoamShaper, all the operator has to do is to select the Serial Cut mode. The cutter will cut each of the drawings one by one, rotating the material as required. It is a fully computerized process, the most time-consuming part being the drawing preparation (which can be facilitated by the use of digital camera pictures and outline generating software, or a 3D scanner).

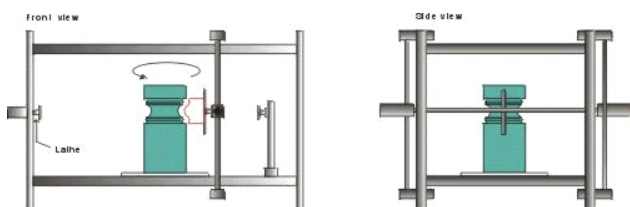
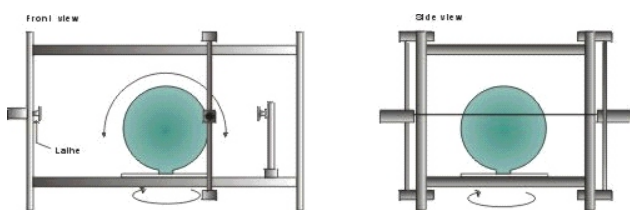
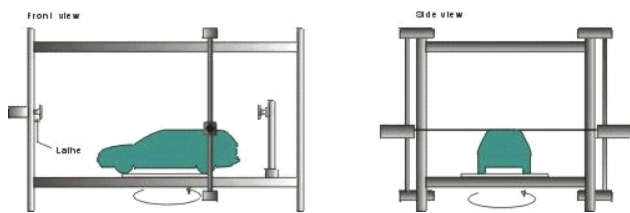
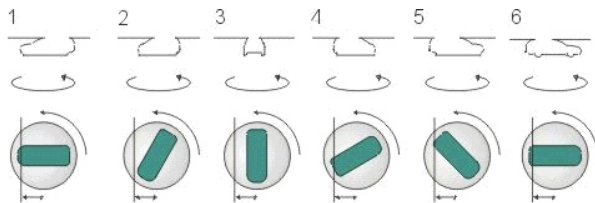



ACCESSORIES: LATHE

Our FoamShaper-controlled, fully-computerized Lathe is an optional device available for most of our foam cutters. The high quality stepper motor fixed to a state-of-the-art planetary transmission turns your material while it's being tooled by either the straight, resistant hot wire or the optional ShapeWire. As opposed to the TurnTable, the Lathe enables you to place the material horizontally and have it supported on both its ends. As a result, cutting a one-piece 10-foot column is an easy task. With the Lathe, the operator can produce all kinds of columns: groove, spiral, etc.

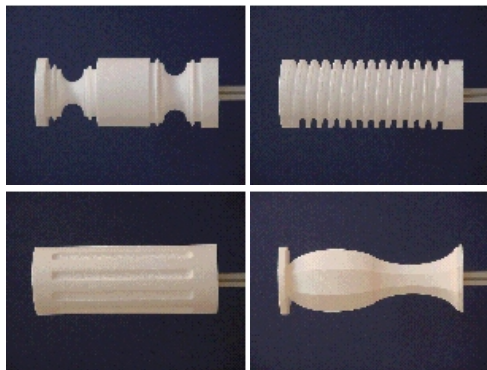
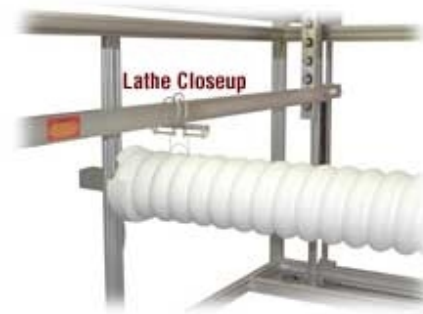

Available cutting modes:

1. Lathe + HotWire

The operator prepares a drawing consisting of two lines only: a straight revolution axis and the art line. The material is mounted on steel spikes (located on the spikes plate and the lathe tail-stock) and the number of solid sides is set in FoamShaper (ranging from 1 up to 2000). The result can be any kind of column: a four-sided one, an eight-sided one, a perfectly smooth one (if the number of cuts set in FoamShaper is large enough) or a twisted one (in which case the material is rotating while the HotWire is cutting; the operator only needs to specify the required rotation and the number of sides). The drawing below illustrates how easy a task cutting a column on our foam cutters is.



Working with the Lathe is a fully automated process controlled by FoamShaper: once the material is mounted, the file loaded and number of sides determined, the foam cutter does everything else and delivers your final product in no time.

2. Lathe + ShapeWire

For this process, the operator pre-bends a piece of 1 mm thick ShapeWire. Once ready and mounted on the ShapeWire Bar, the operator prepares a simple tool-path type of file consisting of a straight revolution axis and the entry and exit lines which tell the cutter where the ShapeWire is to enter and exit the material. To obtain twisted shapes, the required rotation is set in FoamShaper. This process is used to cut groove columns, spirals, threads, and similar types of objects.

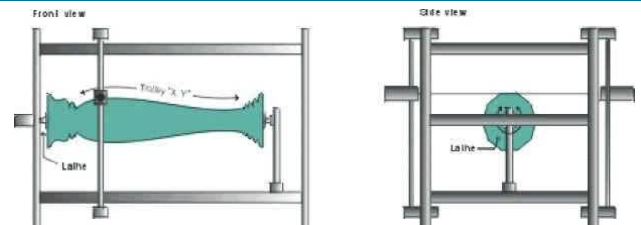
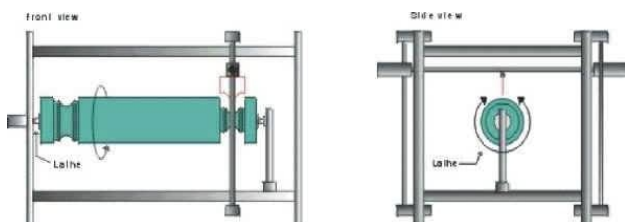



ACCESSORIES: SHAPEWIRE TOOL

ShapeWire Tool is a FoamShaper-controlled, fully-computerized, versatile optional device available for most our foam cutters. When used along with the TurnTable or the Lathe, the ShapeWire Tool enables the operator to cut all kinds of grooved, chiseled, hollow and symmetrical shapes. It uses special 1 mm thick bendable resistant wire which is pre-shaped by the operator and then mounted on a special bar, either horizontally or vertically. The fact that the material is simultaneously being rotated by the Lathe or the TurnTable means there is an almost unlimited number of shapes you can achieve.

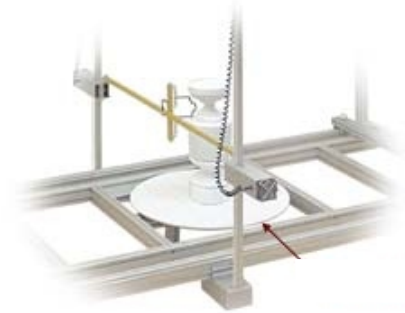
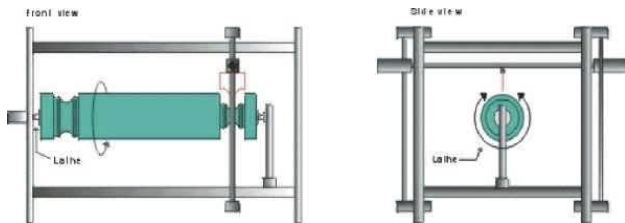

Available cutting modes:

(both can be done with either the Lathe or the TurnTable)

In both cases, the operator starts by pre-bending a piece of 1 mm thick ShapeWire and mounting it on the ShapeWire Bar (which is plugged into the electronic controller and is fully controlled by FoamShaper).

1. Enter-Rotate-Exit

This process offers unlimited possibilities and consists of six basic steps illustrated at the bottom of this page:

1. A piece of ShapeWire pre-bent to a required shape
2. A drawing (revolution axis + entry-exit line)
3. A piece of foam
4. FoamShape configuration
5. Cutting process
6. Final product

The material is mounted on the TurnTable (can be placed horizontally on the Lathe as well) and the ShapeWire Cutting Mode is selected in FoamShaper. Once you click "Start", the pre-bent ShapeWire enters the material, the material makes a 360-degree rotation, the ShapeWire exits the material and in approximately 30 seconds you are done.

2. Along the Path

A similar process in which a pre-bent wire is used to cut grooves or flutes in a piece of foam. Spiral or thread cuts are done in the very same way. All the operator has to do is to prepare a single drawing consisting of a revolution axis and the ShapeWire travel path (often a single line) and to enter the required rotation (if any).

1	2	3	4	5	6



ACCESSORIES: INDEPENDENT AXIS CONTROL

Our **Independent Axis Control with the unique Unlimited Wire Length Change** is a very unique feature making your cutter even more versatile. Now apart from regular 2D cuts, rotary cuts and serial cuts, your foam cutter can also cut tapered shapes or any other shape with two different path lines at the two ends of the cutting wire. You want the left trolley to cut a circle and the right one to cut a square at the same time? Got it!

Basic features:

- * available in all one-wire models
- * **tensometer-controlled unlimited wire length change feature (unique on the market)**
- * USB support
- * new-type ARM processor module-based electronic controllers
- * **advanced software-based wire tension regulation**
- * simple two-color drawings support
- * **material width and position calculations**
- * redesigned trolleys
- * safe and convenient wiring tracks
- * will cut all kinds of tapered shapes

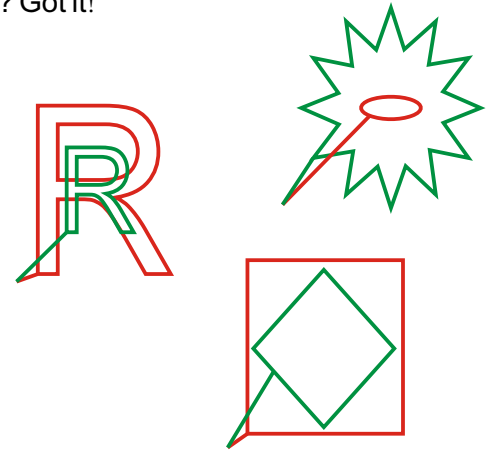

sample two-color drawings

How does it work?

The resistant cutting wire is stretched between two trolleys. On one end it's fixed to a tensometer constantly measuring and monitoring the wire tension and sending current info to the electronic controller. On the other end, the wire is spooled on a large roll fixed to a motor. The required wire tension is set in the software and then during a cut, as the trolleys move independently the tensometer constantly checks the tension, sends the signals to the controller which spools or unspools the wire on the other end to maintain the required tension regardless of trolleys' position. This is a far superior solution over what's offered by our competitors. The first and most important difference is that the trolleys' offset is unlimited, meaning that e.g. the front trolley can stay in the lower left position while the back trolley travels all the way to the upper right corner. Complex as the constant spooling/unspooling may sound, it's all taken care of by our software and the electronic controller; all the operator has to do is to install the wire (and this has always been easy) and set the required tension in the software.

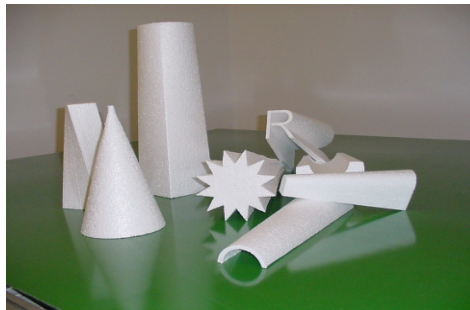



ACCESSORIES: DOUBLE-WIRE = 2 CUTTING WIRES

Available in all T series MegaPlot foam cutters, the DoubleWire option is an affordable way of doubling your foam cutter's output. With the DoubleWire option installed on your cutter, there is an additional wire/fan housing placed above the standard one. This means you can cut with two wires simultaneously, i.e. two identical shapes will be cut at the same time.

The height of the extra wire/fan housing can be adjusted so that the distance between the two cutting wires can be set to any value between 95mm and 610mm. Of course, you may still cut any shapes you wish with just one wire and install the second wire only when required.

DoubleWire is now available in both spring and pneumatically tensioned cutters!

Note: DoubleWire and ShapeWire Tool are not compatible. Only one of these two tools can be ordered for a given T series cutter.

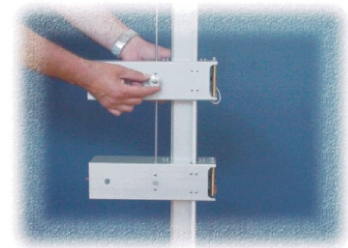

ACCESSORIES: PNEUMATIC WIRE TENSIONING

Pneumatic Wire Tensioning comes standard in all MegaPlot foam cutters 3.0-meter wide or wider. It is also available at an additional charge in our 2.5-meter wide units. While the industry standard spring tensioning proves sufficient in narrow machines, once the wire length reaches 3 meters it is almost impossible to stretch it properly with a spring. That is why all our widest cutters come with Pneumatic Wire Tensioning and Titanium Alloy Wire which make it possible to increase the wire tension app. 3 times and as a result to double the cutting speed as well as obtain much better cutting quality.

Pneumatic Wire Tensioning is available in all SingleWire, DoubleWire and MultiWire cutters 2.5-meter wide or wider.

Note: while an air compressor is required to tension the wires in a foam cutter equipped in pneumatic wire tensioning, it is not included. Please make sure to provide your own standard, small size compressor with the tank of at least a few liters (the bigger the tank the less often it will turn on). Recommended pressure is app. 5-6 BAR (0.5-0.6 MPa). You'll need fittings that will fit a plastic/rubber hose-pipe with the inner dia of 4mm and outer dia of 6mm. Please contact us if further details are required.

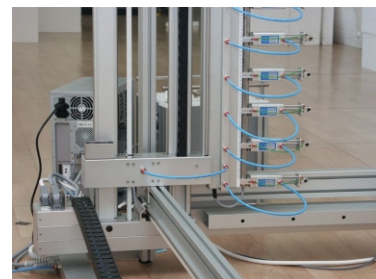
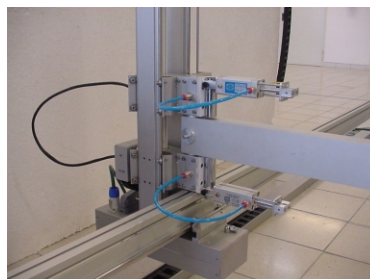



FOAMSHAPER SOFTWARE

All our foam cutters come with our in-house written FoamShaper software. Although user-friendly, this is a versatile, innovative and highly configurable application.

FoamShaper features include:

- HPGL.plt and dxf support (CorelDraw, AutoCAD, etc.)
- object auto-linking (if not linked manually by the designer)
- 3D RAW support (see next page for details)
- scaling
- on-screen cutting simulation
- full cutting control procedure
- advanced duplication module
- complete parameters control: cutting speed, transfer speed, temperature, angle pause, etc.)
- production details (cutting time, width, height, total path length)
- unlimited number of process libraries (saves all parameters for a given project)
- Windows OS full compatibility (including Win XP)

UNLIMITED FREE UPGRADES

The FoamShaper application is included in the price of your foam cutter. If a new version becomes available (new OS or file-type support, new features, interface or algorithm improvements), you get it free.

It does not matter whether you are cutting a single letter or a highly complicated project.

Our FoamShaper software will help you cut just about anything in any way you want.

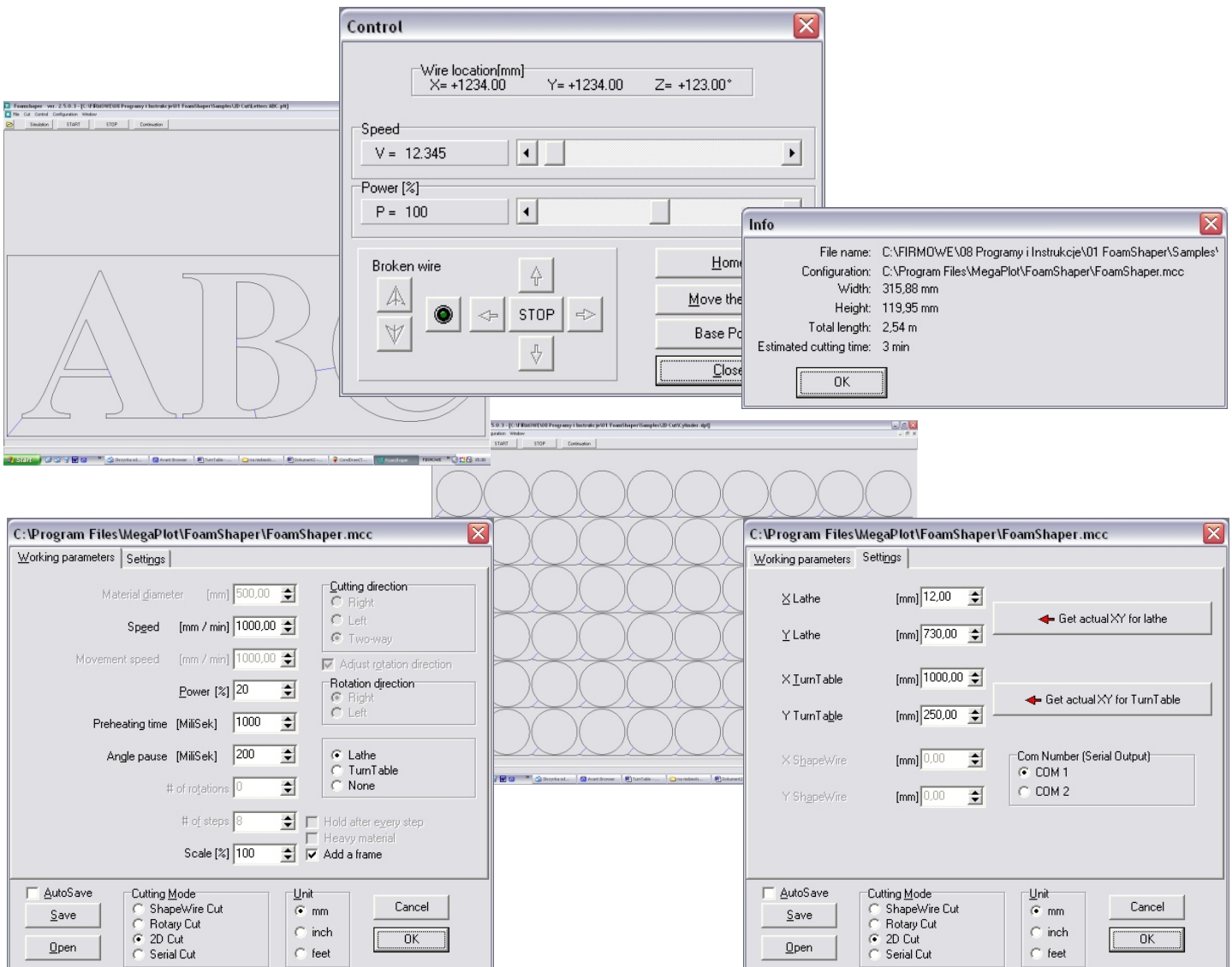



FOAMSHAPER SOFTWARE - NEW FEATURE: 3D RAW SUPPORT

A new, unique and exciting feature in FoamShaper software for creating Serial Cut files from 3D RAW models.

From now on it's gonna be granny-simple to cut a 3D shape out of a 3D model on any MegaPlot foam cutter equipped with a TurnTable.

Requirements: a MegaPlot foam cutter with a TurnTable and a 3D RAW model

Procedure: You start with a 3D model in Rhino3d or any other 3D software with RAW support (or you download free models from the internet), then you load it into FoamShaper and set the required # of steps/facets (the more the smoother the shape but the longer the cut will take) and click Cut

Yes, it's that simple and it's a free upgrade to all existing MegaPlot customers. So, if you already have a MegaPlot cutter, please e-mail us to receive this latest FoamShaper upgrade for free and start cutting your 3D shapes right away. If you don't have a MegaPlot foam cutter yet, go and get one!

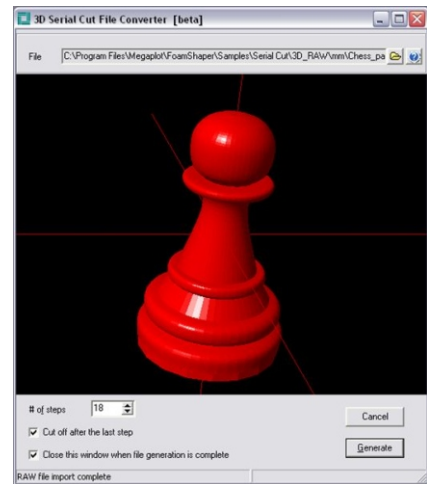
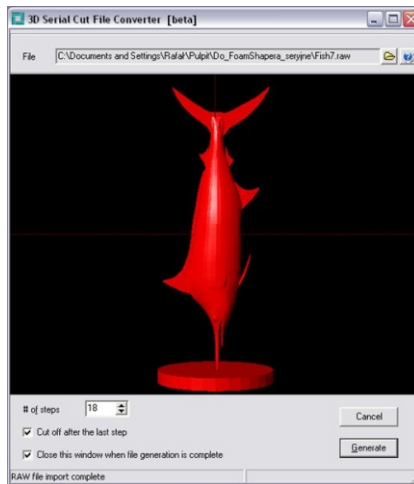
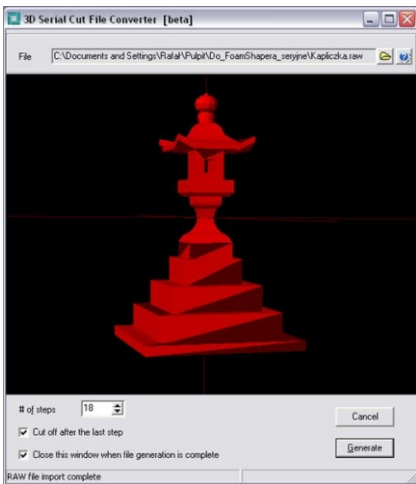

Above: 3D RAW models created in Rhino3D and opened in FoamShaper

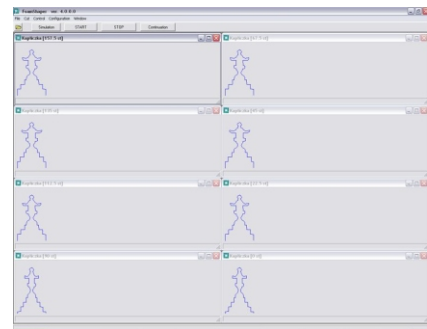
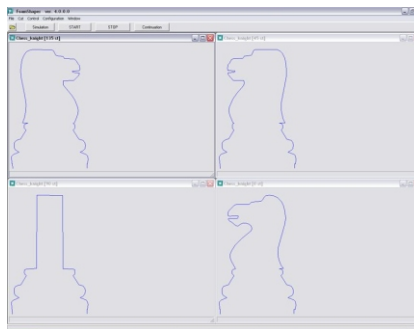
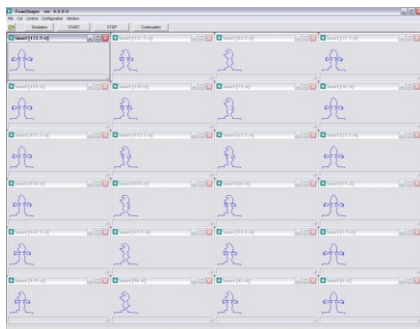

Above: Toolpaths automatically generated in FoamShaper



Above: Shapes cut in foam



RESISTANT CUTTING WIRES

The resistant hot wire reaches the temperature of a few hundred Celcius degrees during cutting. Depepding on the width of the foam cutter (i.e. length of the cutting wire) we offer resistant wires of the following diameters: 0.15, 0.25, 0.45 and 0.55mm. Each MegaPlot foam cutter comes with a free 100-gram spool of the cutting wire.

The P 60 series cutters and most of the T series cutters come with the standard NiCr wire. Depending on the parameters the operator sets, this wire should last for app. 5-10 hours of work. It is inexpensive and is perfectly suitable for everyday applications.



The MW cutters and the widest T series cutters with pneumatic wire tensioning come with the custom-made, highest quality Titanium Alloy Wire NICR01. Although slightly more expensive than regular NiCr wire, Titanium Alloy Wire NICR01 breaks less often (on average, it lasts 5-6 times longer than NiCr wire) and is much more stretch resistant at high temperatures. As a result, it can be used with a stronger tensioning spring or pneumatic tensioning which results in much higher cutting speeds and improved cutting quality. It is available at an additional charge for all our units 1.3 meter wide or wider.

FOAM - EPS & XPS

There are two tpy of foam suitable for tooling with a hot wire foam cutter:

Expanded polystyrene (EPS) is perhaps more common in everyday life — it is the white foam found in drink cups, coolers, insulation, product packaging, etc. It is made up of over 95 percent air and less than 5 percent of polystyrene. The styrene pellets are heated with steam so that they expand rapidly and form a block of low density foam. This kind of foam is inexpensive and light—it usually weights between 15-30 kg per cubic meter. Although it does not degrade under normal circumstances, it is being often recycled.

Extruded polystyrene (XPS) has the same chemical composition as the expanded polystyrene foam, yet it is manufactured in a different way, and as a result this foam — having smaller air pockets — is denser and more homogenous. It is often pink, blue, green, etc. The extruded polystyrene foam is perfect for making any kind of displays.

Why foam?

There is a number of reasons for which the above two kinds of foam have such a wide range of applications. Foam is:

- * inexpensive
- * light
- * perfect for both indoors and outdoors
- * suitable for a variety of coatings (water-based paints, cement-based coatings, metal coatings, etc.)
- * durable— if coated properly, can virtually last for years





WARRANTY

We are proud to offer complete 5-year warranty on all MegaPlot foam cutters - something our competitors rarely do.

Basic warranty terms:

1. The warranty covers all electronic and mechanical parts as well as software.
2. The only thing it does not cover is the cutting wire (but the 0.1kg spool you receive with the machine is likely to last longer than the warranty).
3. All replacement parts are provided free of charge on EXW (ex-works) basis from our factory in Poland.
4. Most replacement parts are shipped to customers on the very same day they are requested.

That's it, there is no small print...

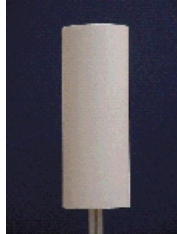



IT'S ALL ABOUT R&D...

Recent news (visit www.megaplot.com for up-to-date information)

- **3D RAW support in FoamShaper!** From now on it's granny-simple to cut any 3D shape out of a 3D model on any MegaPlot foam cutter equipped with a TurnTable. It's simple and it's free for all MegaPlot users! Visit our website for more details and stay ahead of your competitors with this unique feature!
- **New language support.** Our FoamShaper software is now available in 11 **languages**: Chinese, English, French, German, Hungarian, Italian, Polish, Spanish, Slovakian, Romanian and Russian. Please contact us to receive the latest FoamShaper free of charge.
- Check out our **new Accessories section @ www.megaplot.com** for details on TurnTable, Lathe, ShapeWire Tool, DoubleWire, Pneumatic Wire Tensioning, TitaniumWire or our latest and very unique Independent Axis Control with Unlimited Wire Length Change.
- The much-awaited **Independent Axis Control with the unique Unlimited Wire Length Change** feature is finally available for sale. It features motor-controlled unlimited wire length change, a unique solution not found on any competitors' machines offering unlimited possibilities in creating all kinds of tapered shapes.
- Check out our finest **Titanium Alloy Wire**. It is custom-produced for MegaPlot and is available for all our machines. It has very special characteristics and as a result it lets you cut with higher speeds, obtain better quality and is app. 10 times more durable than the standard wires used on competitors' machines.

MEGAPLOT IN NUMBERS

Our factory features over **2000** square meters of production area.
MegaPlot was founded in **1995** .
We have sold over **1500** foam cutters so far.
T-series units max. speed: **500** cm/min.
Our widest foam cutter had a **400** cm long wire.
P-series units max. speed: **280** cm/min.
MW-series units max. speed: **100** cm/min.
MegaPlot has customers in over **50** countries.
MegaPlot has **39** distributors worldwide.
We're currently offering **27** models of foam cutters.
of wires in the MW-series units: **10** pcs.
Max. # of motors in a MegaPlot cutter: **9** /foam cutter.
We have customers on **6** continents.
All our foam cutters come with **5** -year warranty.
Our standard lead time: **3** weeks.
Our customers consider us the # **1** foam cutters manufacturer.





FREQUENTLY ASKED QUESTIONS

How can I get order a MegaPlot machine?

Please contact us via e-mail (office@megaplot.com.pl), phone (+48 693 707 575) or fax (+48 32 291 08 72). If we have a distributor in your area, we will forward your enquiry to them. If we do not have a distributor in your country, we will be more than happy to assist you directly from our HQ.

What is the lead time for a MegaPlot machine?

Usually it is app. 3-4 weeks.

What are the acceptable payment methods?

When purchasing directly from MegaPlot (this may differ if you purchase from one of our distributors), you can make the payment either via a money transfer to our account (after we complete your unit but before it is shipped) or a Letter of Credit (L/C).

What is included in the price of the machine?

foam cutter - electronic controller - a 100-gram spool of wire - FoamShaper controlling software - assembly manual - operational manual - 5-year warranty.

What is not included in the price?

PC with a free serial port (USB for selected models) - graphics software with HPGL.plt (e.g. CorelDraw), dxf (e.g. AutoCad) or RAW (e.g. Rhino3D) support.

What is the warranty for MegaPlot machines?

All MegaPlot foam cutters are covered by a complete 5-year warranty (EXW, ex-works Poland).

Whom do I contact when servicing is required?

Either the distributor you purchased the machine from, or MegaPlot - if you purchased directly from us.

Who is responsible for the machine during the freight?

If we organize the shipment, we take full responsibility for any damages that may happen during the freight.

Is the set-up complicated? Will I need a professional installer?

No. All our units come with step-by-step assembly manuals and can be assembled in 2-4 hours (depending on the model) by anyone with basic manual skills. The operation manual also provided with the machine will get you started on the same day you assemble the machine. Although not necessary, installation and training can also be performed by a MegaPlot technician at an additional charge.

Whom do I contact for technical support?

You can count on us no matter what the problem is. Just send us an e-mail or give us a call and we will do all we can to solve the problem asap. When sending an e-mail with a technical question or a drawing problem, please make sure to include as much information as possible: info on the machine, software version, serial number, installation date, your location, etc.

How durable is the resistant cutting wire in foam cutters?

The standard NiCr wire needs to be changed every 5-10 hours of cutting (depending on your cutting parameters). The TitaniumAlloy wire needs replacing every 40-50 hours of work. Note: the durability of the wire depends strongly on the cutting parameters you set. The higher the temperature, the shorter the lifespan of the wire.

What maintenance do the foam cutters require?

Our foam cutters do not require any special maintenance. We do suggest though that you clean the running tracks with a dry soft cloth once a year or so. The machine requires no lubrication.

For more information on our equipment, please visit our website @

www.MEGAPLOT.com

CONTACT INFO

Phone: +48 693 707 575

Fax: +48 32 291 08 72

E-mail office@megaplot.com

Working hours: Mon-Fr: 8 a.m. - 4 p.m. GMT +1

Mailing address:

MegaPlot
ul. Chemiczna 12
41-205 Sosnowiec
Poland

Geographical location/GPS:

N 50° 17' 48.14"
E 19° 08' 31.96"



Copyright by:  **MEGAPLOT**
FOAM CUTTERS & ROUTER TABLES PRODUCER